



Designation: G30 – 22

Standard Practice for Making and Using U-Bend Stress-Corrosion Test Specimens¹

This standard is issued under the fixed designation G30; the number immediately following the designation indicates the year of original adoption or, in the case of revision, the year of last revision. A number in parentheses indicates the year of last reapproval. A superscript epsilon (ϵ) indicates an editorial change since the last revision or reapproval.

1. Scope

1.1 This practice covers procedures for making and using U-bend specimens for the evaluation of stress-corrosion cracking in metals. The U-bend specimen is generally a rectangular strip that is bent 180° around a predetermined radius and maintained in this constant strain condition during the stress-corrosion test. Bends slightly less than or greater than 180° are sometimes used. Typical U-bend configurations showing several different methods of maintaining the applied stress are shown in Fig. 1.

1.2 U-bend specimens usually contain both elastic and plastic strain. In some cases (for example, very thin sheet or small diameter wire) it is possible to form a U-bend and produce only elastic strain. However, bent-beam (Practice G39 or direct tension (Practice G49)) specimens are normally used to study stress-corrosion cracking of strip or sheet under elastic strain only.

1.3 This practice is concerned only with the test specimen and not the environmental aspects of stress-corrosion testing, which are discussed elsewhere (1)² and in Practices G35, G36, G37, G41, G44, G103 and Test Method G123.

1.4 The values stated in SI units are to be regarded as standard. The values given in parentheses after SI units are provided for information only and are not considered standard.

1.5 *This standard does not purport to address all of the safety concerns, if any, associated with its use. It is the responsibility of the user of this standard to establish appropriate safety, health, and environmental practices and determine the applicability of regulatory limitations prior to use.*

1.6 *This international standard was developed in accordance with internationally recognized principles on standardization established in the Decision on Principles for the Development of International Standards, Guides and Recom-*

mendations issued by the World Trade Organization Technical Barriers to Trade (TBT) Committee.

2. Referenced Documents

2.1 *ASTM Standards:*³

- E3 Guide for Preparation of Metallographic Specimens
- G1 Practice for Preparing, Cleaning, and Evaluating Corrosion Test Specimens
- G35 Practice for Determining the Susceptibility of Stainless Steels and Related Nickel-Chromium-Iron Alloys to Stress-Corrosion Cracking in Polythionic Acids
- G36 Practice for Evaluating Stress-Corrosion-Cracking Resistance of Metals and Alloys in a Boiling Magnesium Chloride Solution
- G37 Practice for Use of Mattsson's Solution of pH 7.2 to Evaluate the Stress-Corrosion Cracking Susceptibility of Copper-Zinc Alloys
- G39 Practice for Preparation and Use of Bent-Beam Stress-Corrosion Test Specimens
- G41 Practice for Determining Cracking Susceptibility of Metals Exposed Under Stress to a Hot Salt Environment
- G44 Practice for Exposure of Metals and Alloys by Alternate Immersion in Neutral 3.5 % Sodium Chloride Solution
- G49 Practice for Preparation and Use of Direct Tension Stress-Corrosion Test Specimens
- G103 Practice for Evaluating Stress-Corrosion Cracking Resistance of Low Copper 7XXX Series Al-Zn-Mg-Cu Alloys in Boiling 6 % Sodium Chloride Solution
- G123 Test Method for Evaluating Stress-Corrosion Cracking of Stainless Alloys with Different Nickel Content in Boiling Acidified Sodium Chloride Solution
- G193 Terminology and Acronyms Relating to Corrosion

3. Terminology

3.1 For definitions of corrosion-related terms used in this practice, see Terminology G193.

¹ This practice is under the jurisdiction of ASTM Committee G01 on Corrosion of Metals and is the direct responsibility of Subcommittee G01.06 on Environmentally Assisted Cracking.

Current edition approved May 1, 2022. Published May 2022. Originally approved in 1972. Last previous edition approved in 2016 as G30 – 97 (2016). DOI: 10.1520/G0030-22.

² The boldface numbers in parentheses refer to a list of references at the end of this standard.

³ For referenced ASTM standards, visit the ASTM website, www.astm.org, or contact ASTM Customer Service at service@astm.org. For *Annual Book of ASTM Standards* volume information, refer to the standard's Document Summary page on the ASTM website.

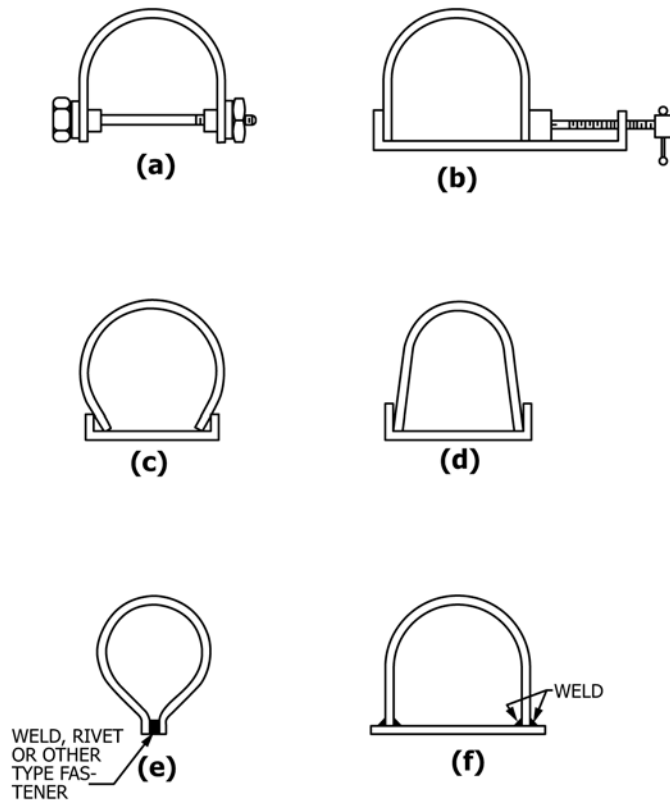

FIG. 1 Typical Stressed U-bends

4. Summary of Practice

4.1 This practice involves the stressing of a specimen bent to a U shape. The applied strain is estimated from the bend conditions. The stressed specimens are then exposed to the test environment and the time required for cracks to develop is determined. This cracking time is used as an estimate of the stress corrosion resistance of the material in the test environment.

5. Significance and Use

5.1 The U-bend specimen may be used for any metal alloy sufficiently ductile to be formed into the U-shape without mechanically cracking. The specimen is most easily made from strip or sheet but can be machined from plate, bar, castings, or weldments; wire specimens may be used also.

5.2 Since the U-bend usually contains large amounts of elastic and plastic strain, it provides one of the most severe tests available for smooth (as opposed to notched or pre-cracked) stress-corrosion test specimens. The stress conditions are not usually known and a wide range of stresses exist in a single stressed specimen. The specimen is therefore unsuitable for studying the effects of different applied stresses on stress-corrosion cracking or for studying variables that have only a minor effect on cracking. The advantage of the U-bend specimen is that it is simple and economical to make and use. It is most useful for detecting *large differences* between the stress-corrosion cracking resistance of (a) different metals in the same environment, (b) one metal in different metallurgical conditions in the same environment, or (c) one metal in several environments.

6. Hazards

6.1 U-bends made from high strength material may be susceptible to high rates of crack propagation and a specimen containing more than one crack may splinter into two or more pieces. Due to the highly stressed condition in a U-bend specimen, these pieces may leave the specimen at high velocity and can be dangerous.

7. Sampling

7.1 Specimens shall be taken from a location in the bulk sample so that they are representative of the material to be tested; however, the bulk sampling of mill products is outside the scope of this standard.

7.2 In performing tests to simulate a service condition it is essential that the thickness of the test specimen, its orientation with respect to the direction of metal working and the surface finish, etc., be relevant to the anticipated application.

8. Test Specimen

8.1 *Specimen Orientation*—When specimens are cut from sheet or plate and in some cases strip or bar, it is possible to cut them transverse or longitudinal to the direction of rolling. In many cases the stress-corrosion cracking resistance in these two directions is quite different so it is important to define the orientation of the test specimen.

8.2 *Specimen Dimensions*—Fig. 2 shows a typical test specimen and lists, by way of example, several dimension combinations that have been used successfully to test a wide range of materials. Other dimensional characteristics may be

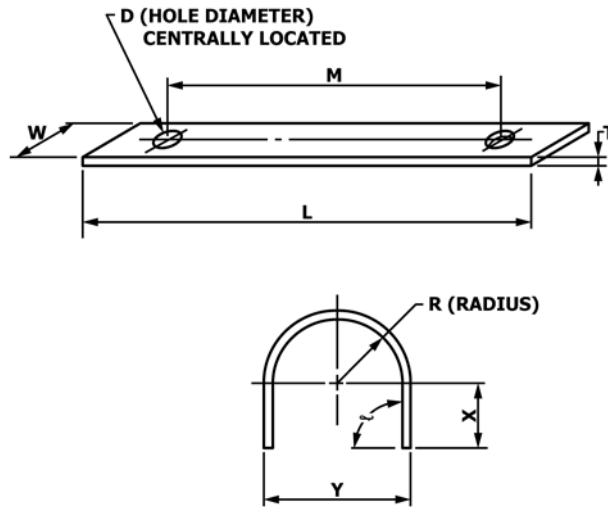

Examples of Typical Dimensions (SI Units)

Example	L, mm	M, mm	W, mm	T, mm	D, mm	X, mm	Y, mm	R, mm	α , rad
a	80	50	20	2.5	10	32	14	5	1.57
b	100	90	9	3.0	7	25	38	16	1.57
c	120	90	20	1.5	8	35	35	16	1.57
d	130	100	15	3.0	6	45	32	13	1.57
e	150	140	15	0.8	3	61	20	9	1.57
f	310	250	25	13.0	13	105	90	32	1.57
g	510	460	25	6.5	13	136	165	76	1.57
h	102	83	19	3.2	9.6	40	16	4.8	1.57

FIG. 2 Typical U-Bend Specimen Dimensions (Examples only, not for specification)

used as necessary. For example, some special types of U-bend configuration have been used for simulating exposure conditions encountered in high temperature water environments relative to the nuclear power industry. These include double U-bend (2) and split tube U-bend (or reverse U-bend) (3) specimens.

8.2.1 Whether or not the specimen contains holes is dependent upon the method of maintaining the applied stress (see Fig. 1).

8.2.2 The length (L) and width (W) of the specimen are determined by the amount and form of the material available, the stressing method used, and the size of the test environment container.

8.2.3 The thickness (T) is usually dependent upon the form of the material, its strength and ductility, and the means available to perform the bending. For example, it is difficult to manually form U-bends of thickness greater than approximately 3 mm (0.125 in.) if the yield strength exceeds about 1400 MPa (200 ksi).

8.2.4 For comparison purposes, it is desirable to keep the specimen dimensions, especially the ratio of thickness to bend radius, constant. This produces approximately the same maximum strain in the materials being compared (see 9.3). However, it does not necessarily provide tests of equal severity if the mechanical properties of the materials being compared are widely different.

8.2.5 When wire is to be evaluated, the specimen is simply a wire of a length suitable for the restraining jig. It may be desirable to loop the wire rather than use just a simple U-shape (4).

8.3 Surface Finish:

8.3.1 Any necessary heat treatment should be performed before the final surface preparation.

8.3.2 Surface preparation is generally a mechanical process but in some cases it may be more convenient and acceptable to chemically finish (see 8.3.4).

8.3.3 Grinding or machining should be done in stages so that the final cut leaves the surface with a finish of 0.76 μm (30 $\mu\text{in.}$) or better. Care must be taken to avoid excessive heating during preparation because this may induce undesirable residual stresses and in some cases cause metallurgical or chemical changes, or both, at the surface. The edges of the specimen should receive the same finish as the faces.

8.3.4 When the final surface preparation involves chemical dissolution, care must be taken to ensure that the solution used does not induce hydrogen embrittlement, selectively attack constituents in the metal, or leave undesirable residues on the surface.